

BISOMAC210-1P600

European version **1-phase**
electric power specification

Electric Traction Hoist Operator's Manual

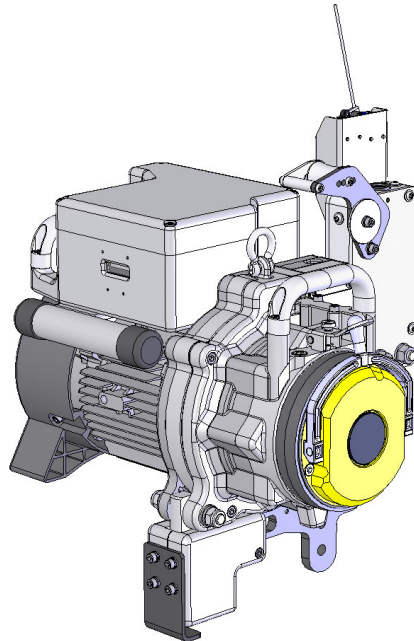

WARNING

Read manual before operating this Hoist. Failure to follow the safety precautions and instructions in this manual could result in serious injury, death or damage to the Hoist.

 **WARNING**

- This manual does not apply to single point suspended platform.
- All operators must read and understand this manual before operating this equipment.
- All operators must be fully trained in the use of the equipment including its safety features and authorized.
- Each day before the equipment is used, the operator must carry out the Daily Tests and Inspections described in Section 7 of this manual to confirm that equipment is in a normal and safe operating condition.
- Only authorized and physically fit operators shall operate the equipment.
- Any operation in violation of these instructions is at the operator's own risk and may result in serious injuries.
- Keep this manual with the hoist at all times.
- Only use spare parts and steel wire rope provided and/or specified by NIHON BISOH CO., LTD.
- Use only machinery or incorporated component, which has been declared to be in conformity with provisions of Directive 98/37/EC and national implementing.

MANUFACTURER: NIHON BISOH CO., LTD.

Contents

10.3.0. READ BEFORE USING BISOMAC210 TRACTION HOIST	4	
10.3.1. FOR SAFE USE	7	
10.3.1.1 General	7	
10.3.1.2 Maintenance	7	
10.3.1.3 Categories of Safety Instructions	8	
10.3.2. SPECIFICATIONS	12	
10.3.2.1 BISOMAC210	12	
10.3.2.2 WIRE ROPE	13	
10.3.2.3 POWER CABLE	13	
10.3.3. FUNCTIONS and DESCRIPTIONS of each COMPONENTS	14	
10.3.3.1 BISOMAC210	14	
10.3.4. WORK ENVIRONMENT	19	
10.3.5. SET UP INSTRUCTIONS	20	
STEP 1	Installation of Safety Devices to the Hoist	22
STEP 2	Connection of Power and Control Circuit	24
STEP 3	Main Wire Rope Reeving	24
STEP 4	Mounting BISOMAC210	25
STEP 5	Installation of Safety Wire Rope	26
STEP 6	Operation Confirmation of Fall Arrest Device	27
STEP 7	Enforcement of Daily Inspection	27
STEP 8	Install the Supporting Plate for the Upper / Ultimate Limit Switch	27
10.3.6. OPERATION / HANDLING METHODS	29	
10.3.6.1 Carrying BISOMAC210	31	
10.3.6.2 UP/DOWN and Emergency Stop	31	
10.3.6.3 Controlled Descent Lever	32	
10.3.7. DAILY TESTS AND INSPECTIONS	33	
10.3.7.1 Test Procedure of Rigging Metals	35	
10.3.7.2 Test Procedure of Wire Rope	35	
10.3.7.3 Test procedures of Lifting and Emergency Stop	36	
10.3.7.4 Test procedures of Controlled Descent	36	
10.3.7.5 Test procedures of Fall Arrest Detection Device	37	
10.3.7.6 Test procedures of Upper/Ultimate Limit Switch	37	
10.3.8. PERIODIC INSPECTION	38	
10.3.9. TROUBLESHOOTING AT JOB SITE	39	

Hoist Schematic Diagram

10.3.0. READ BEFORE USING BISOMAC210 TRACTION HOIST

This Operator's Manual had been prepared for the safe and proper operation of the **BISOMAC210 Electric Traction Hoist** (referred to as "BISOMAC210"). To understand the usage of the BISOMAC210 Traction Hoist, please refer to the following explanation and system compositions. It is operator's responsibility to be sure that this hoist is used safely and properly.

TSP = Temporary Suspended Platform

TSPs are Suspended access equipment which are temporary installed on a building or structure for specific tasks. TSPs consist of platform and suspension rigs which are assembled prior to use on a work site. They are disassembled and removed from site on completion of the work for which they were installed.

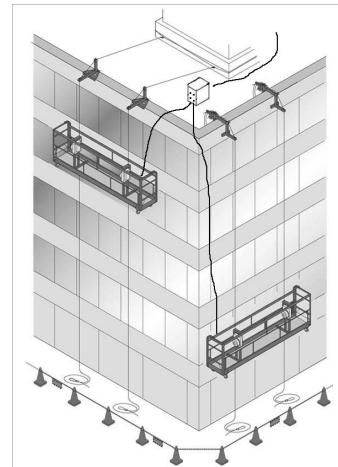

Suspended Platform

The portion of assembly designed to carry person and their equipment.

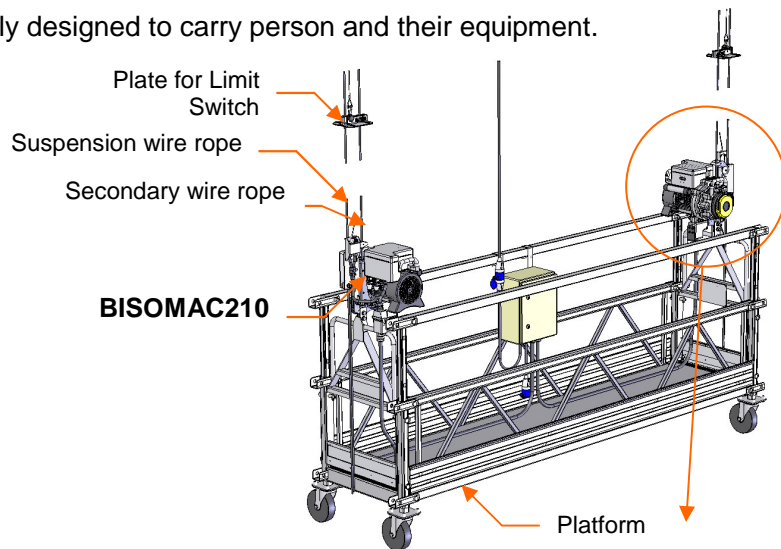

BISOMAC210 Traction Hoist

Assembly through which the wire rope is conveyed as a result of friction between the wire rope and the traction assembly, with no tail load.

Bisomac insist on using all safety devices.

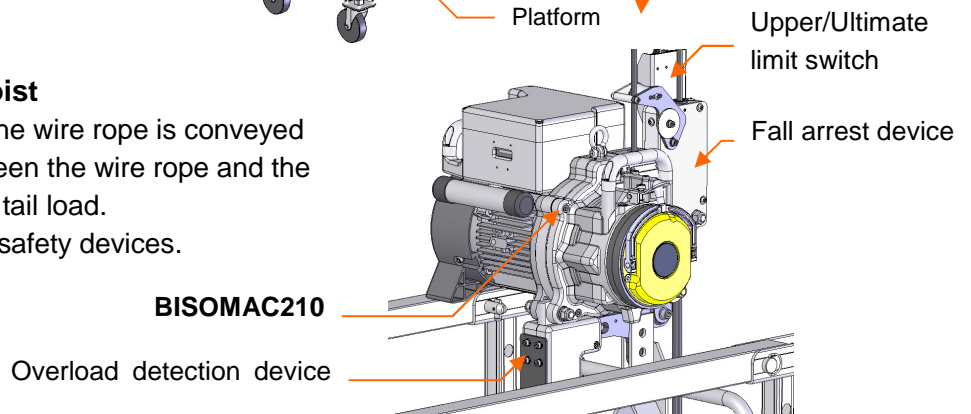

PRECAUTIONS

See European Standard EN1808 for details on Applications that are excluded from the EN1808 and other relevant exclusions.

1. Power Supply to the TSP must be fitted with

- a) Main switch

NOTE: Main switch with key-lock or Junction Box with key-lock shall be provided.

- b) Residual current device (or earth leakage circuit breaker) of 30 mA.

- c) Overcurrent protective device (automatic fuse Type C)

Note: check that the specifications of the electrical supply cable match the power requirement of the platform and will avoid a voltage drop due to cable length.

2. Weather conditions

Temperature range:	-10 degree and +40 degree
Humidity:	less than 75%
Contaminants:	Degree of protection IP54
Max. wind speed:	accordant with SAE user manual
Altitude:	less than 1000 meter

3. Precaution prior use

- a) Before using the equipment, operators must carry out the Daily Tests and Inspections described in Section 7 of this manual and make sure that the equipment is in normal working condition.
- b) Before using the equipment, operators must confirm that there are no obstacles along the movement of the TSP.
- c) Before use the equipment, the suspension system must be checked to ensure the stability of the TSP at all times.
- d) In case the area below the TSP is open to the public, preventive measures have to be taken to safeguard the people below (e.g. barriers, roof protected walkways, etc.)
- e) All hazards related to the platform encountering obstructions are not completely covered by the TSP's safety devices. The operator shall check for obstructions along the travel of the platform.
- f) The Overload Protection may not protect the TSP platform in all configurations. The operator must check that the loading of the platform does not exceed the rated load indicated on the nameplate.
- g) An area on the platform must be available to allow operators to operate the hoist safely.
- h) Use approved personnel harnesses, lanyards, rope grabs, and independent lifelines at all times.

4. Precautions during use

- a) The operators must stop working with the equipment and notify the supervisor if faults, damage to the equipment or other circumstances may jeopardize safety.
- b) A suitable communication between the operator and the supervisor is recommended.
- c) When you leave a platform, shut off the power supply at the main switch and lock it so that no one else can operate it.
- d) When the hoist stops for more than 30 minutes in low temperature, the hoist can be difficult to rise. In that case, allow the hoist 30 seconds to idle or lower the hoist before trying to use.

5. Forbidden Uses

- The BISOMAC210 is not allowed to use for any other purpose than for lifting and lowering a platform.
- The BISOMAC210 is not allowed to use for single point suspended platform.
- Two units or more of the BISOMAC210 are not allowed to use on one wire rope.
- The BISOMAC210 is not allowed to use by inserting a wire rope into the wire rope outlet.
- Do not tight end of suspension wire rope when using BISOMAC210.
- Do not apply more than 20kg discharge resistance to the end of wire rope.
- The BISOMAC210 is not allowed to use as a crane for lifting and lowering materials.
- The BISOMAC210 is not allowed to use as a lifting device of a permanent elevator.
- The BISOMAC210 is not allowed to use as a horizontally pulling traction device.
- The BISOMAC210 is not allowed to use as a medical traction device.
- The BISOMAC210 is not allowed to use in water.

10.3.1. FOR SAFE USE

10.3.1.1 General

This Operator's Manual is applicable to the Nihon Bisoh Co., Ltd manufactured BISOMAC210 Electric Traction Hoist. The BISOMAC210 consists with Hoist Device, Fall Arrest Device, Overload Device and Upper/Ultimate Limit Detection Device.

This Operator's Manual (hereafter referred to as "Manual") had been prepared for safe and proper operation of the BISOMAC210 **1-phase electric power** specification.

1. Read and understand this manual fully before using the BISOMAC210.
2. This BISOMAC210 is designed for vertical ascent and descent of personnel-carrying suspended platforms. The BISOMAC210 should only be used for this purpose.
3. All operators must be fully trained in the use of the equipment including its safety features and authorized.
4. Daily Tests and Inspections described in Section 7 must be performed at the start of each work shift.
5. Use Section 9 troubleshooting guide in this manual to solve problems that may develop with the BISOMAC210. Understand the problem before attempting to solve it.

It is very important that anyone using the BISOMAC210 determine for themselves whether the BISOMAC210 is safe. You must be familiar with the operating characteristics of the BISOMAC210. You must understand how the BISOMAC210 will interact with other equipment and it is very important to confirm safety of the whole platform. You must also be certain not to jeopardize yourself or others, or cause damage to the surroundings, or the BISOMAC210.

10.3.1.2 Maintenance

Handling, maintenance, inspections and repairs of the following products must be performed by trained personnel only who have been read the BISOMAC210 Maintenance Manuals (another sheet).



BISOMAC210 consists of:

- 1) Hoist Device
- 2) Fall Arrest Device
- 3) Overload Device
- 4) Upper/Ultimate Limit Detection Device.

There are individual maintenance manuals for the hoist and safety devices.

10.3.1.3 Categories of Safety Instructions

In this operator's manual, the safety instructions are classified according to risk levels.

Simple	Code word	Meaning
	WARNING	Indicates a potentially hazardous situation which, if not avoided, could result in death or serious injury.
	CAUTION	Indicates a potentially hazardous situation which, if not avoided, may result in minor or moderate injury. It may also be used to show potential damage to property.
	NOTE	Indicates a potentially hazardous situation which, if not avoided, could result in damage of the BISOMAC210.

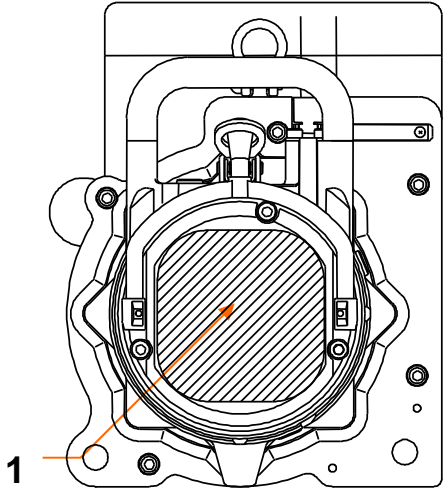
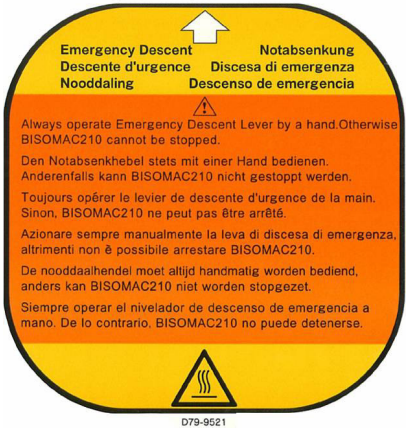

Warning labels attached to Hoists and Devices

The operator must check that the following labels are attached properly and legible.

<Right side surface of BISOMAC210>		
		
Description	Message / <Location>	Label
<p>1. Instruction of Electromagnetic Brake</p>	<p>Electromagnetic Brake</p>	

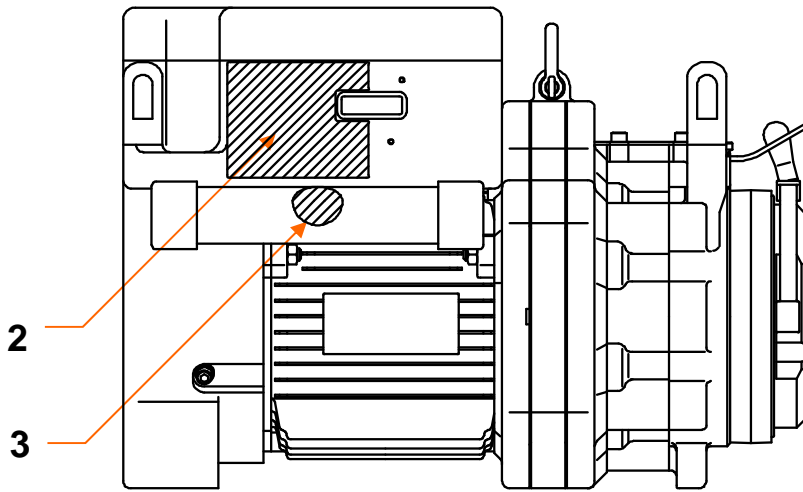

<Front Surface of BISOMAC210>

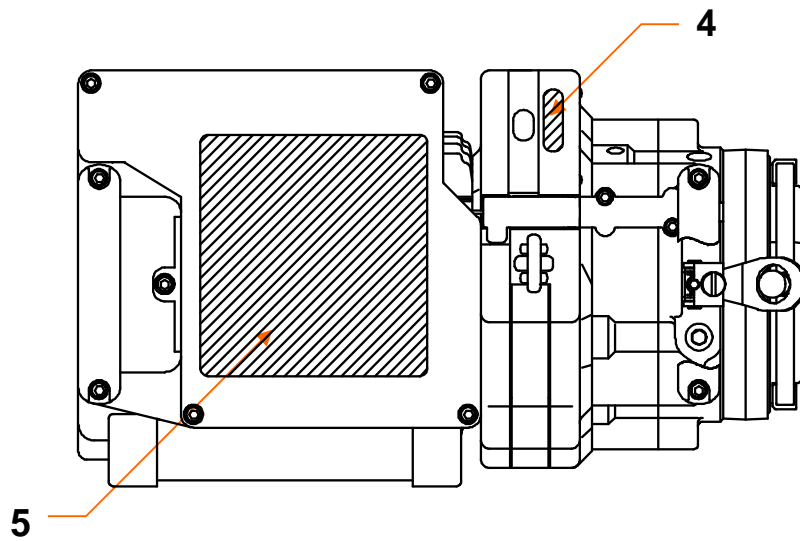

Description	Message / <Location>	Label
<p>2. Instruction in case of hoisting lifting problem</p>	<p>Control Box</p>	<p> If rope stops moving, shut off power immediately to avoid a dangerous situation or bodily injury</p> <p>Wenn der Seildurchlauf im Hebe oder Senkvorang unerwarteter weise stoppt – Anlage sofort abschalten, um eine gefährliche Situation oder Verletzungen zu vermeiden!</p> <p>Si la corde arrête le déménagement, éteindre le pouvoir tout de suite pour éviter une situation dangereuse ou une blessure physique.</p> <p>Se la corda ferma il trasloco, ha chiuso il potere immediatamente per evitare una situazione pericolosa o una fisico lesione.</p> <p>Indien touw bewegen stopt, schakel uit macht onmiddellijk om een gevaarlijke toestand of lichamelijke verwonding te vermijden.</p> <p>Si las paradas del lazo que mueven, apagan el poder de evitar inmediatamente una situación peligrosa o en persona herida.</p>
<p>3. Manual Mark</p>	<p>Operator's manual pipe</p>	<p> D79-9544</p>

<Top Surface of BISOMAC210>



Description	Message / <Location>	Label
4. Instruction of wire rope	Casing A	
4. Instruction of specification and wire rope	Control Box Cover	

<Fall Arrest Detection Device>

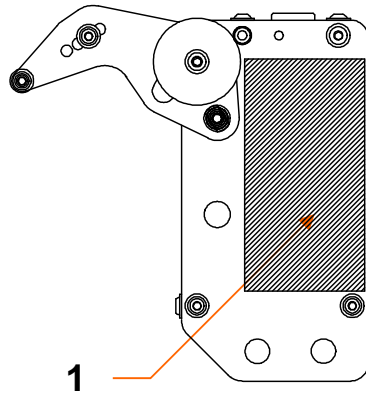

Description	Message / <Location>	Label
<p>1. Fall Arrest Device Instruction</p>	<p>Fall Arrest Device</p>	 <p>Wire Rope Dia Drahtseil-Durchmesser Dia. câble métallique Diam. cavo metallico Diameter stahlkabel Diámetro del cable de acero</p> <p>9 - 9.5mm</p> <p>Capacity Kapazität Capacità Capacitat Capacitat</p> <p>800 KG</p> <p>Activating Angle Aktivierungswinkel Angle d'activation Angolo di attivazione Beek-actiemom Angulo de activación</p> <p><14°</p> <p>D79-9523</p>

<Overload Detection Device>

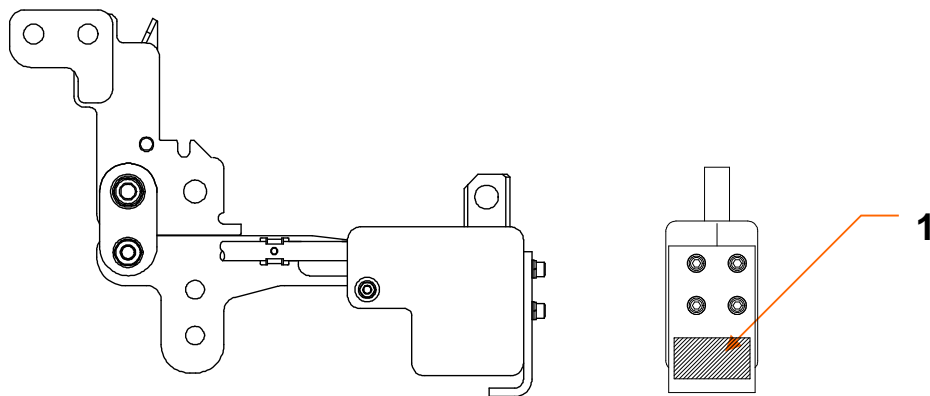

Description	Message / <Location>	Label
<p>1. Instruction of Overload Detection Device</p>	<p>Overload Detection Device</p>	 <p>600 KG</p> <p>D79-9514</p>

10.3.2. SPECIFICATIONS

10.3.2.1 BISOMAC210

10.3.2.1.1 TRACTION HOIST

Maximum Load Capacity	600 kg (W.L.L.)
Voltage	1-phase 230V (50Hz)
Ampere in rated load	7.5A (230V)
Motor Power	1.5KW (4P)
Wire Rope Dia	9mm
Rated Speed	8.5m/min (50Hz)
Noise	64dBA
Protection Construction	IP54
Dimension	640mm (high) x 386 mm (width) x 455mm (depth)
Hoist Self Weight	48.0kg
Weight including safety devices	56.5kg (Slack rope device: 3.5kg Overload device: 4.5kg Limit device: 0.5kg)
Control Method	Central Control Method
MAINTENACNE SPECIFICATIONS	
Maintain every 100 hour of operation hour or no longer than every year. See Maintenance Manual for instructions on maintaining. (this differ from condition of use at work sites, refer Section 4 Work Environment)	
Safety Features	Electromagnetic Brake
	Controlled Descent Device

10.3.2.1.2 SAFETY DEVICES

1. FALL ARREST DEVICE	
Max Rated Load:	800kg (W.L.L.)
Activation Angel:	14 degree (can be adjusted)
Dimension:	246mm (high) x 204 mm (width) x 60mm (depth)
Weight:	3.5kg (will be 4kg include Upper/Ulimate Limit Detection Device)
2. OVERLOAD DETECTION DEVICE	
Max Rated Load:	600kg (W.L.L.)
Activation Load:	750kg (125 % of rated load)
Dimension:	270mm (high) x 375 mm (width) x 93mm (depth)
Weight:	4.5kg
Control Feature:	NO ascending while this device is activated.
Use Voltage	230V
3. UPPER/ULTIMATE LIMIT SWITCHS	
Use Voltage:	230V
Dimension:	146 mm (high) x 80 mm (width) x 46 mm (depth)
Weight:	0.5kg
Control Feature:	NO ascending while the Upper Limit Switch device is activated. NO lifting while the Ultimate Limit Switch is activated due to power shut off automatically.

10.3.2.2 Wire Rope

Wire Rope Classification / construction	TYPE A (Designation)	TYPE B (Recommendation)	TYPE C (Recommendation)
Diameter:	9.0mm	9.4mm	9.2mm
Construction:	4x36WS	4x36WS	5x26
Minimum Breaking Load (actual)	67.2kN (6857kg)	64.9kN (6622kg)	66.8kN (6816kg)
Treatment	Galvanized	Galvanized	Galvanized



WARNING

BISOMAC210 operation requires the use of wire rope described below. Using any other wire rope could cause the platform to fall or tilt, possibly resulting in falls and serious injury or death.

10.3.2. 3 Power Cable

Recommended Type	H07RN-F
Core and Size	3 cores Minimum 4 mm ²
Rated Voltage U ₀ /U	450/750V
Max Length	100 meter (in case of use 4mm² on TSP)

NOTE: Due to the various possible suspended platform loading situations and electric voltage sources, it is not possible to specify the maximum power cable length exactly.

10.3.3. FUNCTIONS AND DESCRIPTIONS OF EACH COMPONENTS

10.3.3.1 BISOMAC210

10.3.3.1 TRACTION HOIST

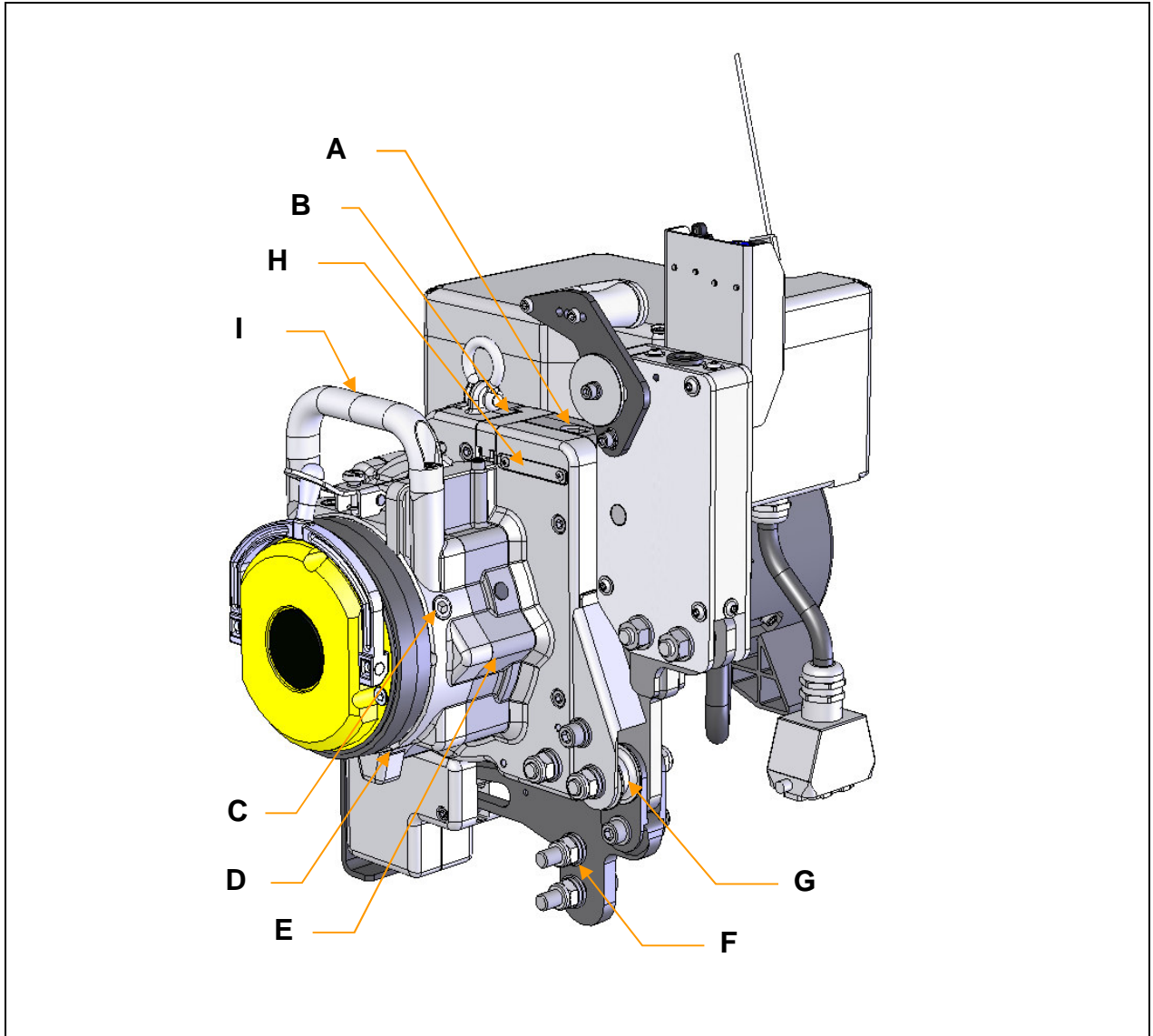

	FUNCTION	DESCRIPTION
A	Suspension Wire Rope Inlet	For inserting the main suspension wire rope
B	Guard Plate for Brake Leads	Protect Brake Leads from damages
C	Fluid Refill Hole	Use when replacing oil
D	Fluid Discharge Hole	Use when replacing oil
E	Gear Box	Gear Box for BISOMAC210
F	Stirrup Fix Bolts	This hole is used to mount the BISOMAC210 to stirrup
G	Guide Roller	Support end of wire rope load
H	Serial Number	BISOMAC210 Serial Number
I	Carrying Handles	Carrying handles for BISOMAC210

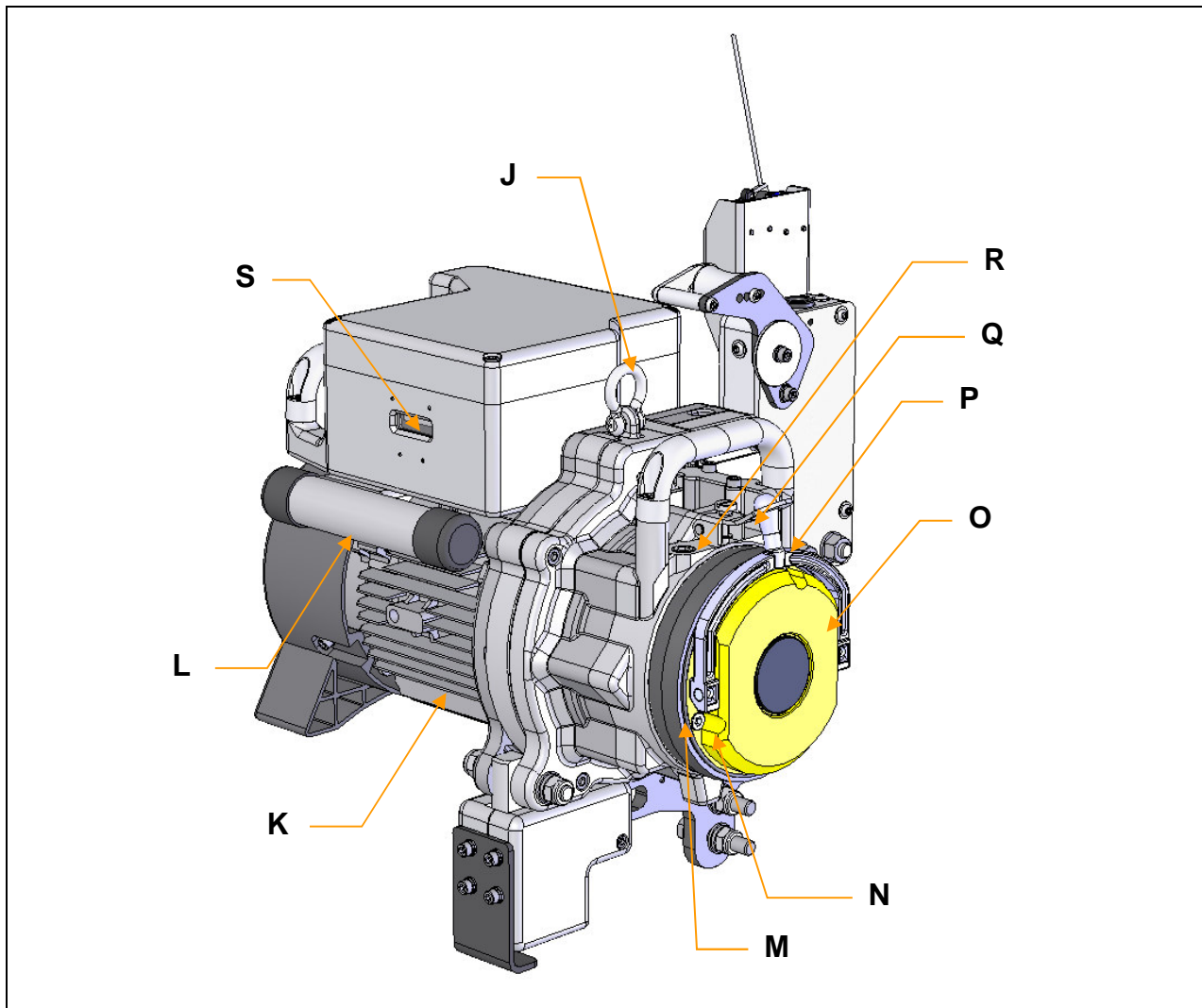

	FUNCTIONS	DESCRIPTIONS
J	Lifting Eyelet for Transportation	Transport of BISOMAC210. Max lifting load is 70kg
K	Electric Motor	BISOMAC210 is powered by electricity through gear drive
L	Pipe of Operation Manual Holder	Keep Operation Manual
M	Protection Cover	Does not allow water and dirt to get into Electromagnetic Brake
N	Water-proof Cap Bolt of Electromagnetic Brake	Cap bolt with sealing to avoid water getting into the Electromagnetic Brake
O	Electromagnetic Brake	Electromagnetic Brake is released when the Operation Button is pressed. The BISOMAC210 stops when the Operation Button is released or the main power is disconnected
P	Controlled Descent Lever	This allows the platform to be lowered at regular speed when electrical power to the BISOMAC210 is lost
Q	Lever Stopper	Prevents misoperation & malfunction of Emergency Descent Lever
R	Fluid Discharge Hole	Use when replacing oil
S	Hour Meter	Shows the BISOMAC's integrated operating hours

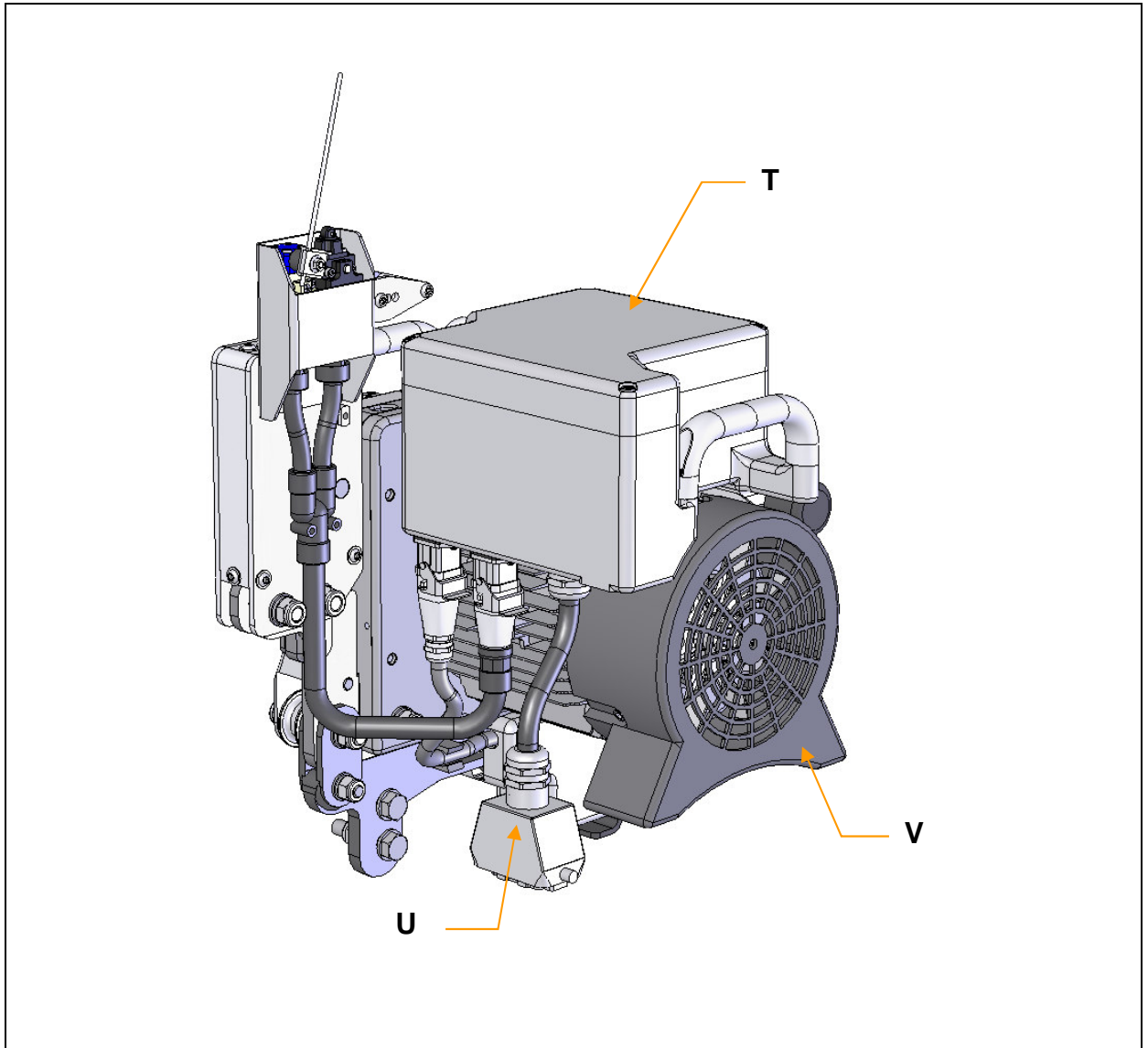

	FUNCTIONS	DESCRIPTIONS
T	Control Box	Electric components are assembled to control BISOMAC lifting
U	Connecting Plug	Connecting cable from Central Control Box to BISOMAC210
V	Fan Cover	Protect operator from rotation of motor and damage

10.3.3.1.2 SAFETY DEVICES

⚠ WARNING

When platform suddenly inclines or falls and the Fall Arrest Device activates, only trained and authorized personnel are allowed to reset this device. Contact the local authorized BISOMAC210 distributor and wait for rescue of the operators on the platform. Improperly resetting the device may result in the platform falling and tilting, allowing persons or things to fall and possibly resulting in serious injury, death or damage.

⚠ WARNING

When the Ultimate Detection Switch activates, only trained and authorized personnel are allowed to reset this device. Contact the local authorized BISOMAC210 distributor and wait for rescue of the operators on the platform. Improperly resetting the device may result in the platform falling and tilting, allowing persons or things to fall and possibly resulting in serious injury, death or damage.

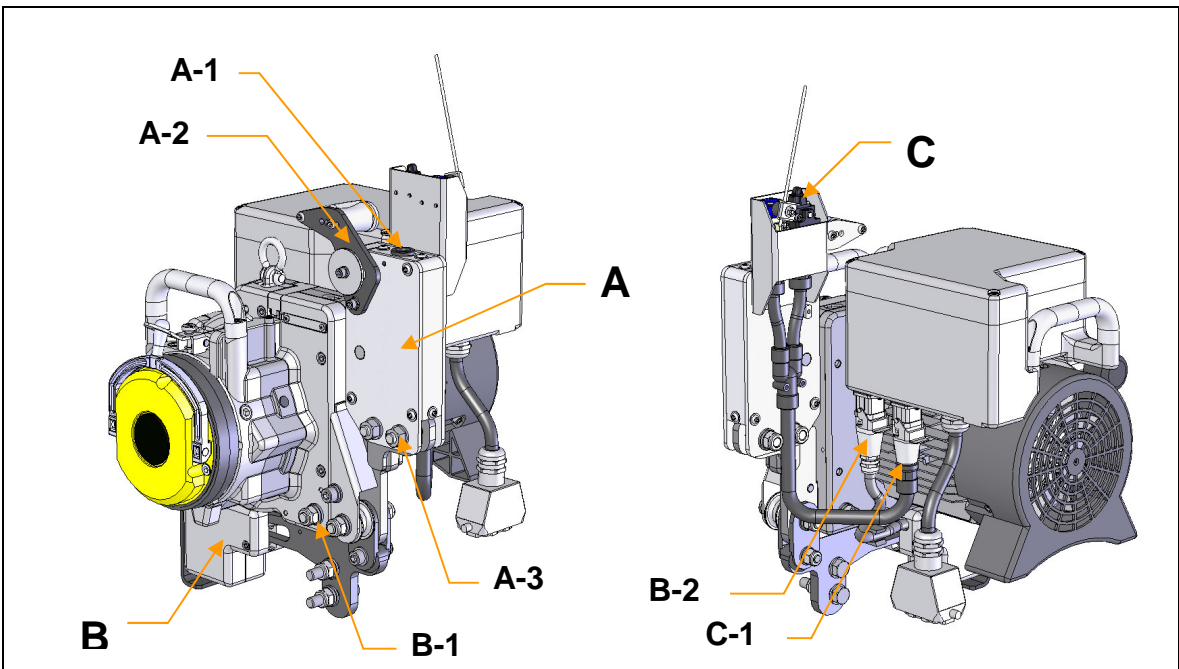

A. Fall Arrest Device

The Fall Arrest Device is designed to engage the safety wire rope when platform angle exceeds pre-set angle or when platform falls suddenly.

DESCRIPTIONS	FUNCTIONS
A-1. Safety Wire Rope Inlet	Insert safety wire rope
A-2. Slack Rope Lever	Detect tilting of platform and let activate Fall Arrest Device

A-3.	Special Bolts for holding Fall Arrest Device	Special Bolts for installing Fall Arrest Device to BISOMAC210
<p>B. Overload Device</p> <p>The Overload Device is designed to protect overload of platform. When load exceeds 750kg applied to rigging portion, this device detects this to prevent the ascending operation of the hoist. Be sure that load should not exceed determined load by each platform.</p>		
DESCRIPTIONS		FUNCTIONS
B-1.	Special Bolts for holding Overload Device (use Q'ty 2 bolts)	Special Bolts for installing Overload Device to BISOMAC210
B-2.	Connector for Overload Device	Connecting cable from Overload Device to BISOMAC210
<p>C. Upper / Ultimate Limit Detection Switch</p> <p>If the upper limit switch activates, hoist cannot ascend even pressing up button. If the upper limit switch does not activate some reason and continue to ascend, the ultimate limit switch activates. Once the ultimate limit switch activate, all operation of a platform is not possible. Contact authorized BISOMAC210 agent and rescue the workers on the platform. Install the supporting plate following "STEP 8 Install the Supporting Plate for the Upper / Ultimate Limit Switch" in Section 5.</p>		
DESCRIPTIONS		FUNCTIONS
C-1.	Connector for Upper / Ultimate Limit Detection Switch	Connecting cable from Upper / Ultimate Limit Detection Switch to BISOMAC210

10.3.4. WORK ENVIRONMENT

Many work environments contain contaminants that could adversely affect the performance of the BISOMAC210 and the Safety devices. Perform the daily tests described in Section 7 to ensure that the BISOMAC210 is operating properly. If contaminants such as paint, epoxy, cement, corrosive chemicals or sand blasting is present at the work site, use the BISOMAC210 protective cover in accordance with instructions and precautions below on this page.

The protective cover may obstruct some or all of the safety warnings and instruction labels on the BISOMAC210. Before operating the BISOMAC210 equipped with the protective cover, the operator must remove the protective cover and read and understand all of the labels on the BISOMAC210. Each new operator must fully understand all warning and instruction labels before operating the BISOMAC210.

WARNING

1. ALWAYS test and inspect (Section 7) the BISOMAC210 on a daily basis especially in work environments contains contaminants. Maintain hoist (see Maintenance Manual) after completing work at each work site to remove dusts and foreign objects inside of the hoist. Improper maintenance may result in the platform falling and tilting, allowing persons or things to fall and possibly resulting in serious injury, death or damage.
2. NEVER use the BISOMAC210 in an explosive atmosphere, under water, or in a marine environment. Especially, use in explosive or wet atmospheres could result in serious injury or death from fire, explosions, or electric shock.

CAUTION

Prolonged use of the BISOMAC210 with the protective cover in place may result in the motor overheating due to restricted air supply. This can cause the BISOMAC210 to stop moving. When using the protective cover, be sure that the fan has an unobstructed air supply. Also, stop the BISOMAC210 to allow the motor to cool.

Note: An explosive atmosphere is one in which flammable gases or vapours or small particles are or may be present in the air in quantities sufficient to produce an explosive or ignitable mixture.

Note: Use the protection cover of the BISOMAC210, when dyed goods such as paints, epoxy resin, cements, and solvents is put on the working environment that uses BISOMAC210 or sand blasting finish etc. are used, otherwise the BISOMAC210 may malfunction.

Note: Use the BISOMAC210's protection cover when BISOMAC210 is exposed to work environment such as paint, freezing temperatures or where water or moisture can enter; to keep the BISOMAC210 from the freezing, otherwise the BISOMAC210 may malfunction.

10.3.5. SET UP INSTRUCTIONS

This section describes procedure for installation of the BISOMAC210 for safety operation. Before attempting set up, read and understand Steps 1 - 8 of this section which describes the installation procedures of the BISOMAC210.

(Warning: Installation)

WARNING

1. DO NOT allow anyone under suspended platform. If necessary, provide protection below the suspended platform to prevent potential serious injury or death to passers-by from falling objects.
2. DO NOT use different types of hoists in the same platform. Otherwise, an operation error may occur from the difference in the hoists' performance (ascending and descending speed, etc.) and the difference of the operation method and the safety unit. This may result in the platform falling or tilting, allowing persons or things to fall or tilt and possibly resulting in serious injury, death or damage.
3. When attaching the BISOMAC210 to the platform, it is necessary to plan how to attach safety devices in advance, otherwise, the safety devices may not activate. Failure to activate may cause serious injury, death or damage.
4. Attach earth leakage breaker to power source and ensure that is properly grounded. Failure to do so increases the risk of electric shock or electrocution.
5. Operators are not allowing opening the central control box, doing so could result in electric shock or death.
6. DO NOT use damaged or cracked power cable and control cables. Doing so could result in electrocution or death.

(Caution: Power and Control Circuit)

CAUTION

1. The Voltage supplied to the BISOMAC210 should not exceed $\pm 10\%$ rated voltage (see Section 2.1 rated voltage specification) while lifting. If the voltage is not in the proper range, the BISOMAC210 may not operate or the motor may overheat and malfunction or create a burn hazard.
Note: The rated voltage range shown above should only be permitted to be temporary and not continuous during use of the BISOMAC210.
2. DO NOT pull power cable and hoist connection cable. The power cable may become damaged and un-usable and may result in serious injury or property damage.

(Warning of Main Wire Rope and Safety Wire Rope)

WARNING

1. The BISOMAC210 operation requires the use of authorized wire rope and the strict adherence to the operation methods and the instructions. If using a wire rope that is not required, the wire rope will have reduced strength and will be served. This may cause the platform to fall or tilt, resulting in falls and serious injury or death.

2. DO NOT expose the wire rope to fire, temperatures above (93□), electrical current, or corrosive atmospheres and chemicals. Doing so will reduce the rope's strength and possibly allow the rope to break. This could result in platform falling or tilting, possibly causing serious injury, death or damage.
 - Discard the wire rope if any damage is evident after completing the project.
 - Replace with new wire rope if the wire rope has a doubt.
 - Discard the wire rope that has been contacted to any of corrosive.
3. The suspension wire rope should be long enough (lifting height plus at least 5 meter to cover the height where the platform is placed on the ground or on the specified area. If the wire rope cannot cover the height where the platform can be placed on a stable area, the wire rope may slip out of the BISOMAC210. This may cause the platform to fall or tilt, and consequently operators or objects might fall, resulting in serious injury, death or damage to operators or passers-by.
4. Install the suspension wire rope and the safety wire rope with the range of distance $100 \pm 10\text{mm}$. If this range exceed, the fall arrest device function may be obstruct and this may cause the platform to fall or tilt, and consequently workers or objects might fall, resulting in possible death or injury to workers or passers-by.
5. Operating the BISOMAC210 with a wire rope having a kink or deformation may interfere with the up and down movement of the BISOMAC210 and cause damage to the hoist and possibly sever the wire rope. This may cause the platform to fall or tilt, and consequently operators or objects might fall, resulting in serious injury, death or damage to operators or passers-by.
6. When fixing the suspension wire rope and the safety wire rope to the building material, be sure that these wire ropes are not contacting any sharp edge. Otherwise, if the wire rope becomes heavily loaded and severed by a sharp edge, this may cause the platform to fall or tilt, and consequently operators or objects might fall, resulting in serious injury, death or damage to operators or passers-by.
7. The wire rope should be able to go through the inside of the BISOMAC210 freely. Inconsistent winding speed suggests the wire rope or the BISOMAC210 may be damaged. Stop operation at once and replace the wire rope or the BISOMAC210. If the use of damage BISOMAC210 is continued, the wire rope may be severed or the BISOMAC210 may stop. This may cause the platform to fall or tilt, and consequently operators or objects might fall, resulting in serious injury, death or damage to operators or passers-by.
8. DO NOT fasten or apply load to the tail end of the suspension wire rope discharged from the BISOMAC210. Otherwise, the internal parts of the BISOMAC210 will become extremely worn and the wire rope may be damaged or severed. This may cause the platform to fall or tilt, and consequently operators or objects might fall, resulting in serious injury, death or damage to operators or passers-by.

 **CAUTION**

DO NOT put your hand near the wire rope inlet when self-reeving the wire rope and moving the platform up and down. Otherwise, your hand may be caught in the opening along with the wire rope, causing serious injury.

(Caution: BISOMAC210 Installation)

⚠ CAUTION

DO NOT throw or drop the BISOMAC210. The BISOMAC210 may become damaged and cannot be used and may result in serious injury or property damage.

STEP1 Installation of Safety Devices to the Hoist

Install the Fall Arrest Device and Overload Detection Device to Hoist using the instructions below. Refer section 3.1 for assembled condition.

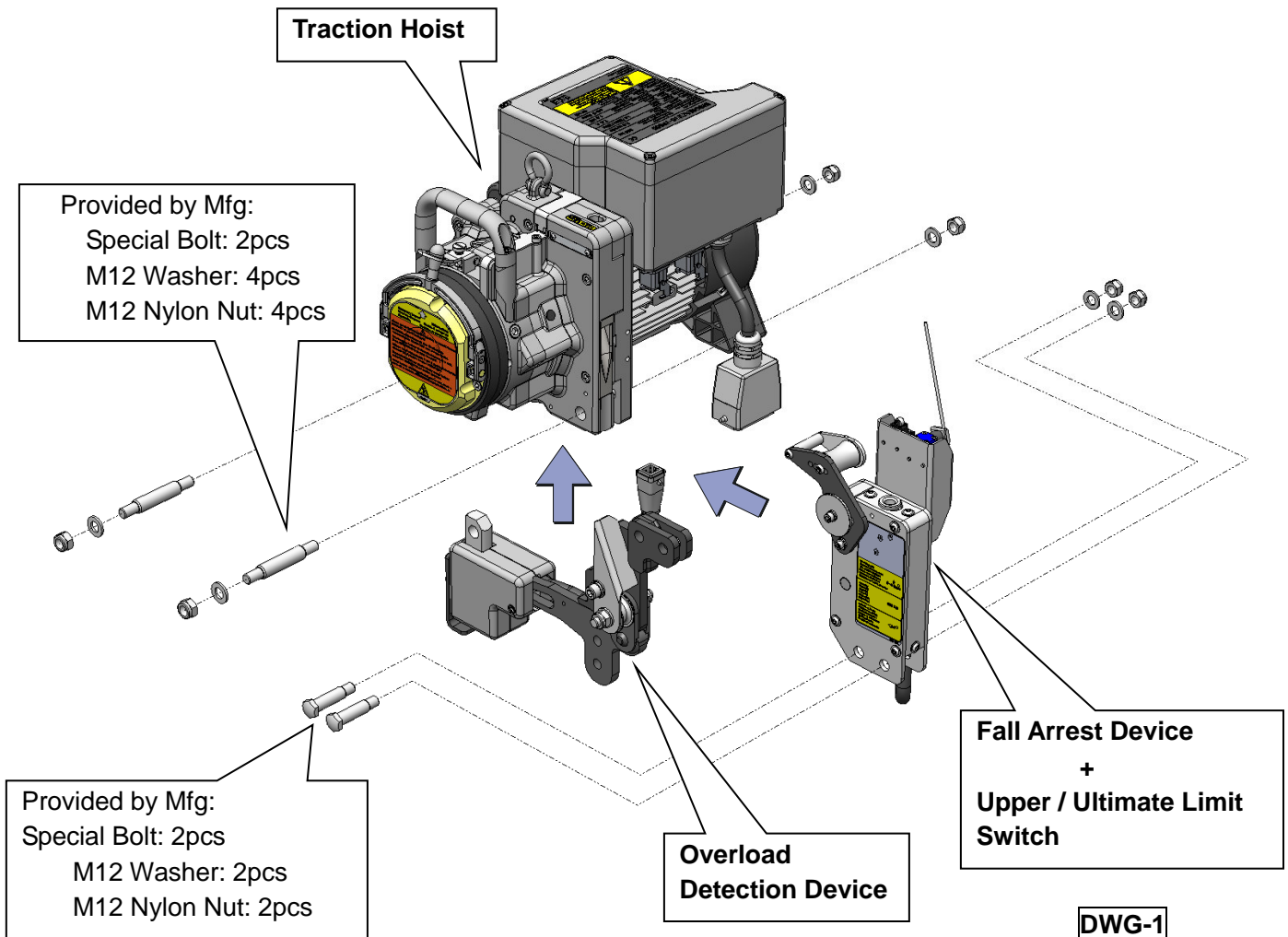

1. Insert the Overload Detection Device into the Hoist from the bottom as shown in DWG-1 and tighten with 2 Fix Bolts, 4 Washers and 4 Nylon Nuts provided by manufacturer. Use Torque Wrench to tighten the Bolts.

Torque Standard:76 N·m (770 kgf·cm)

2. Insert the Fall Arrest Device into the Hoist from the top as shown in DWG-1 and tighten with 2 Special Bolts, 2 Washers, and 2 Nylon Nuts provided by manufacturer.

Torque Standard: 76 N·m (770 kgf·cm)

3. Connect the Plug of each Safety Device the Hoist as shown in DWG-2.

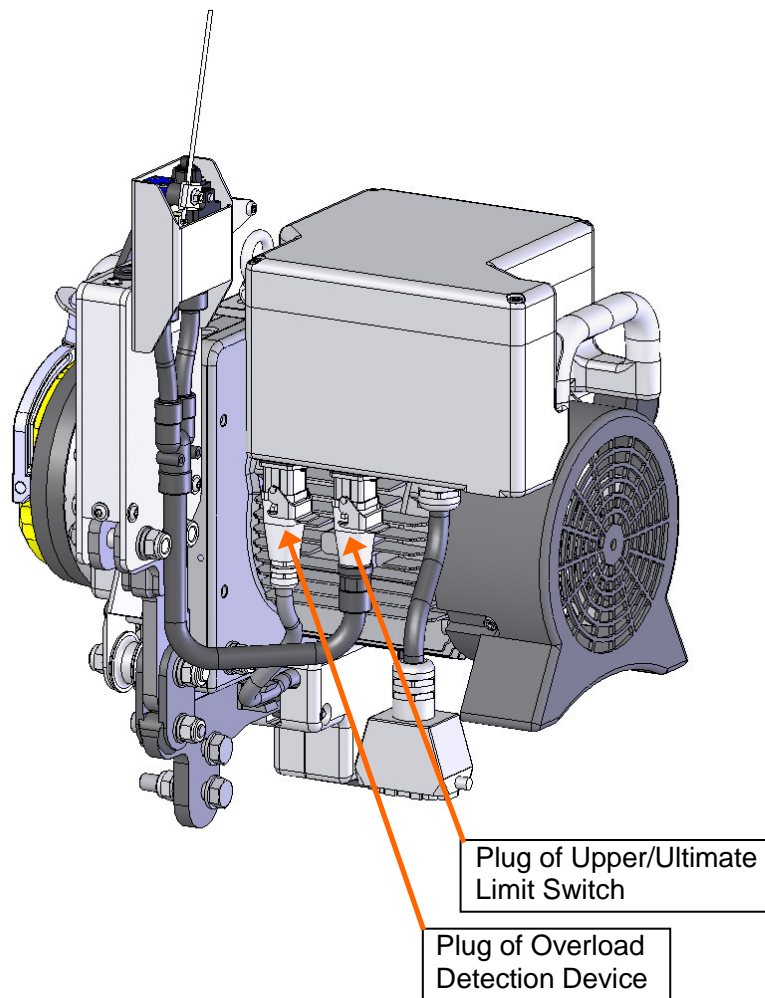

DWG-2

STEP 2 Installation of Central Control Box and connection of Power and Control Circuit

1. Necessary power is **7.5A** per BISOMAC210.
2. Ensure that the emergency stop button of central control box and the interlock of the safety devices are reset.
3. Connect the hoist connector cable to BISOMAC210 connection cable.
4. Ensure that current capacity and size of circuit fuse is adequate. (Refer section 2 specification)

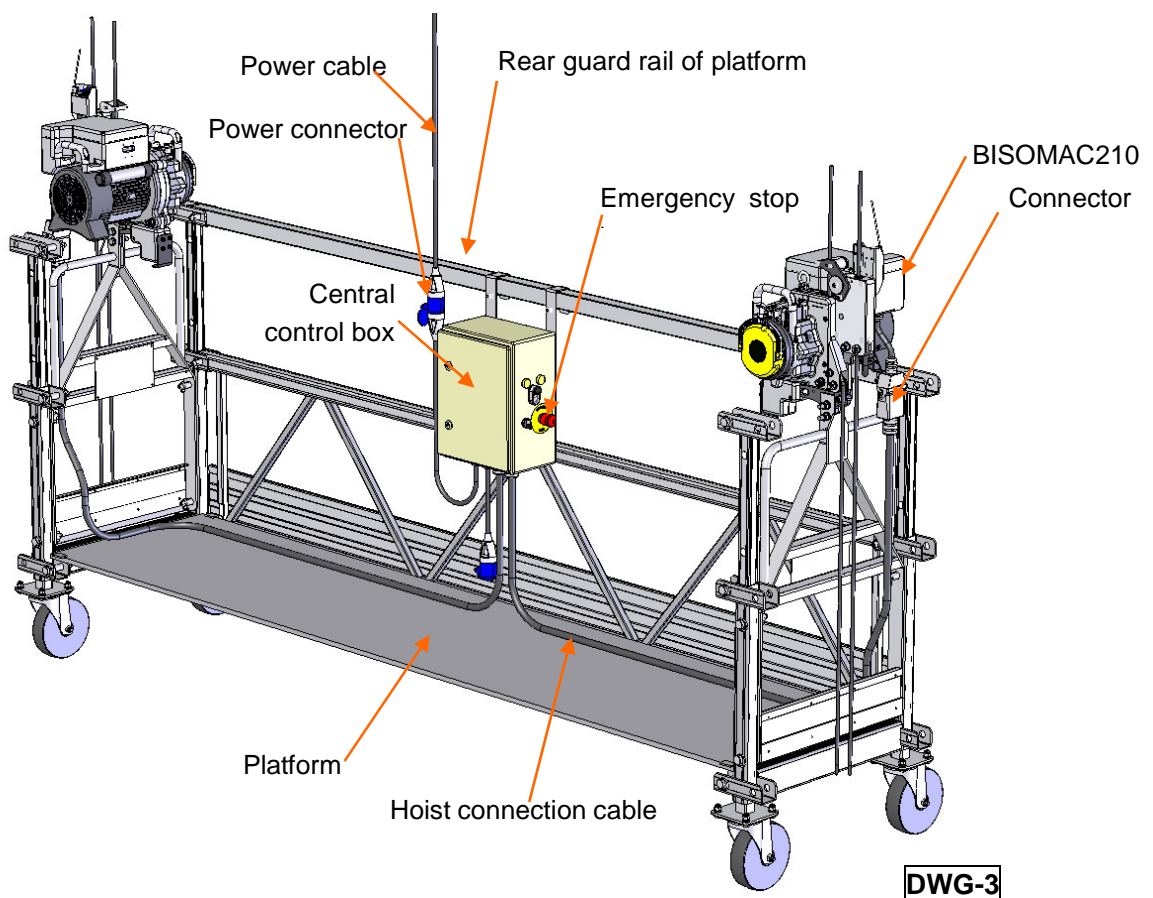

STEP 3 Main Wire Rope Reeving

1. Insert the bullet end of the wire rope approximately 15cm into the suspension wire rope inlet of the BISOMAC210.
2. Press the "UP" button while maintaining downward pressure on the wire rope, until self-reeving starts.
3. Make sure the wire rope can freely exit the BISOMAC210 and is not blocked by any parts.
4. Install the suspension wire rope so that an interval of platform side and rigging metal side become equal.

5. To avoid run off the suspension wire rope from the BISOMAC210, make the loop on the end of the suspension wire rope and fixed by the clamp as shown in DWG-4.

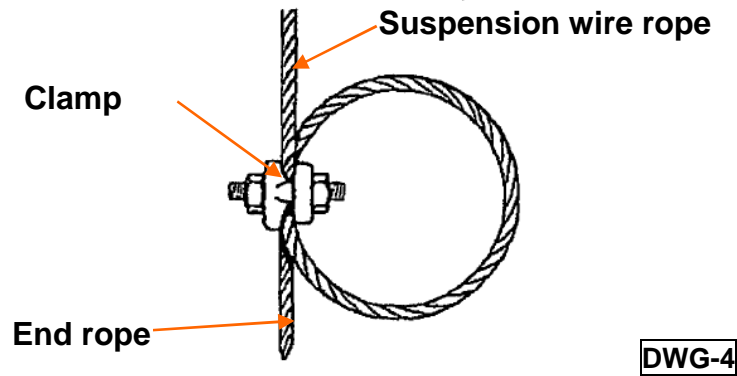

STEP 4 Mounting BISOMAC210 to the platform

Press the UP button of the central control box to lift the BISOMAC210 from ground to become the hole of frame of the overload device and the hole of the stirrup one line and then fix the stirrup of platform with M12 bolt and self-locking nut provided by manufacturer. Position the Fall Arrest Device the outside of the platform as shown in the DWG-5.

Torque Standard: 76 N·m (770 kgf·cm)

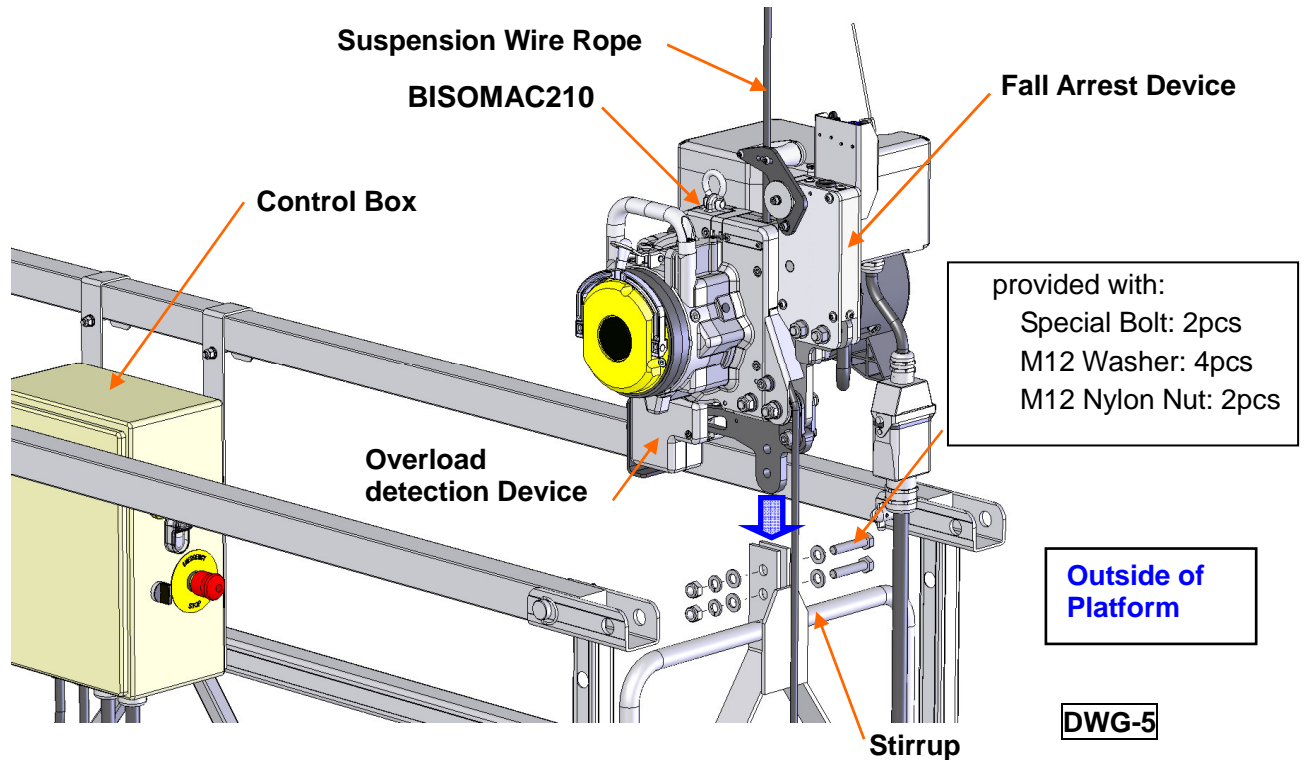

STEP 5 Installation of Safety Wire Rope

1. Lift the platform by using the BISOMAC210 until the suspension wire rope is straight.
2. Reeve the safety wire rope into the Fall Arrest Device inlet until and the safety wire rope is straight and make sure the safety wire moves smoothly without resistance in the device.
3. Install counterweight (more than 10kg) to end of the safety wire rope to protect lift up of the safety wire rope.
4. Install the suspension wire rope and the safety wire rope with the range of distance $100 \pm 10\text{mm}$. (Refer DWG-6)

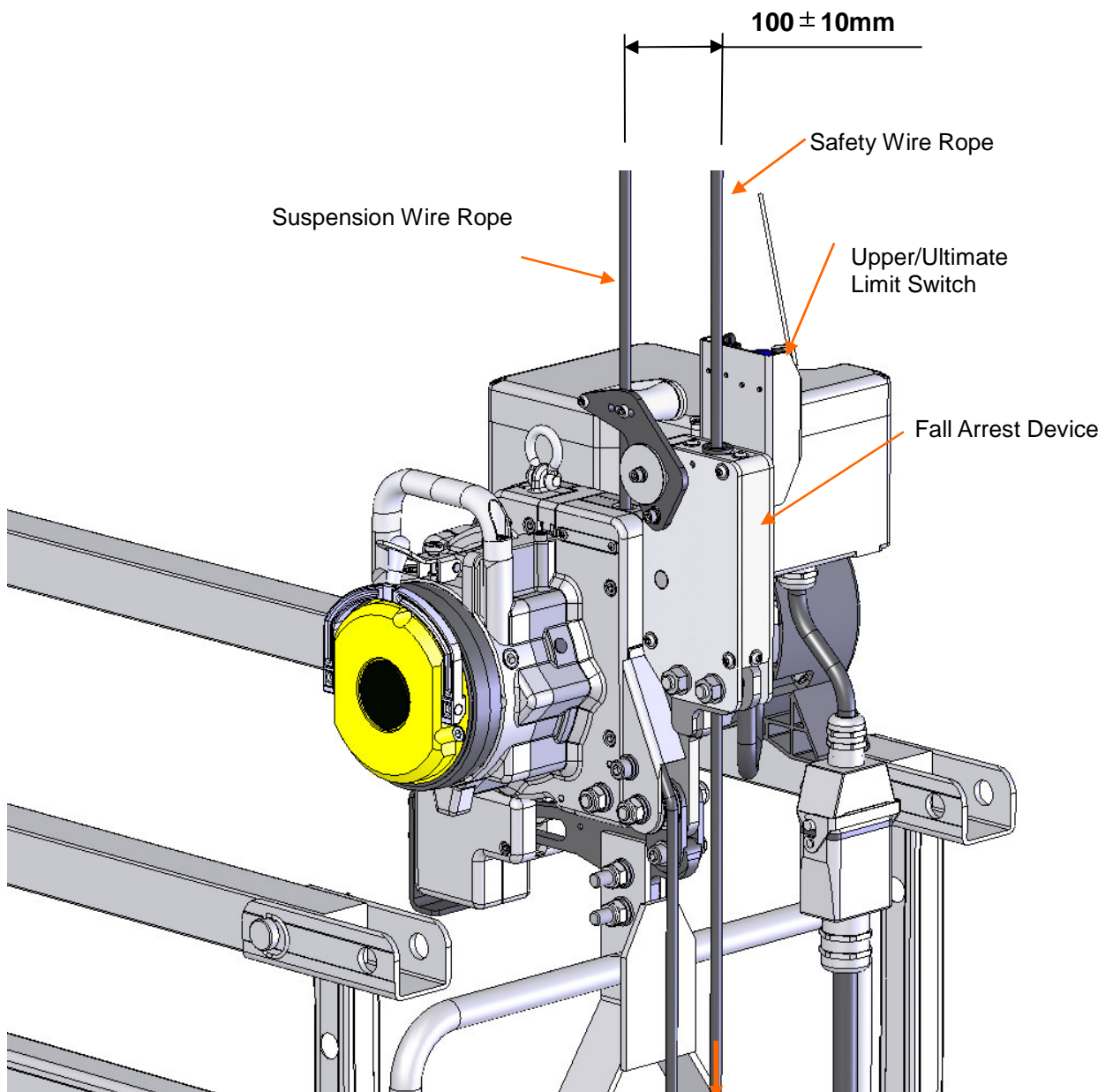

Rope Exit
* require more
than 10 kg weight

DWG-6

STEP 6 Operation Confirmation of Fall Arrest Device

(Caution: Fall Arrest Detection Device Operation Check)

! CAUTION

1. Ensure that there is no object, which is easy to roll and slip in platform before attempt to incline. If there is object, remove it, the object, which slipped, hits a worker and is in danger of being hurt.
2. Confirm that a floor of a platform does not get wet and slippery.
3. Perform tilting angle adjustment shall be adjusted by authorized personnel.

Perform the following procedure to confirm that the Fall Arrest Device activates within 14 degree.

1. Raise the platform approximately 2 m from ground.
2. Descend one side of hoist by operating the central control box.
3. Make sure that Fall Arrest Device engages the safety wire rope.

If the angle of the platform inclination exceeds 14 degree, ask the authorized trained personnel for adjustment.

Refer the attached maintenance manual for the adjustment.

Raise the platform to reset the Fall Arrest Device after testing.

STEP 7 Perform of Daily Inspection

Before installing the supporting plate for the upper / ultimate limit switch, perform the Section 7 Daily Test and Inspection.

STEP 8 Install the Supporting Plate for the Upper / Ultimate Limit Switch

Set the supporting plate with approximately 200mm distance as shown in DWG-7.

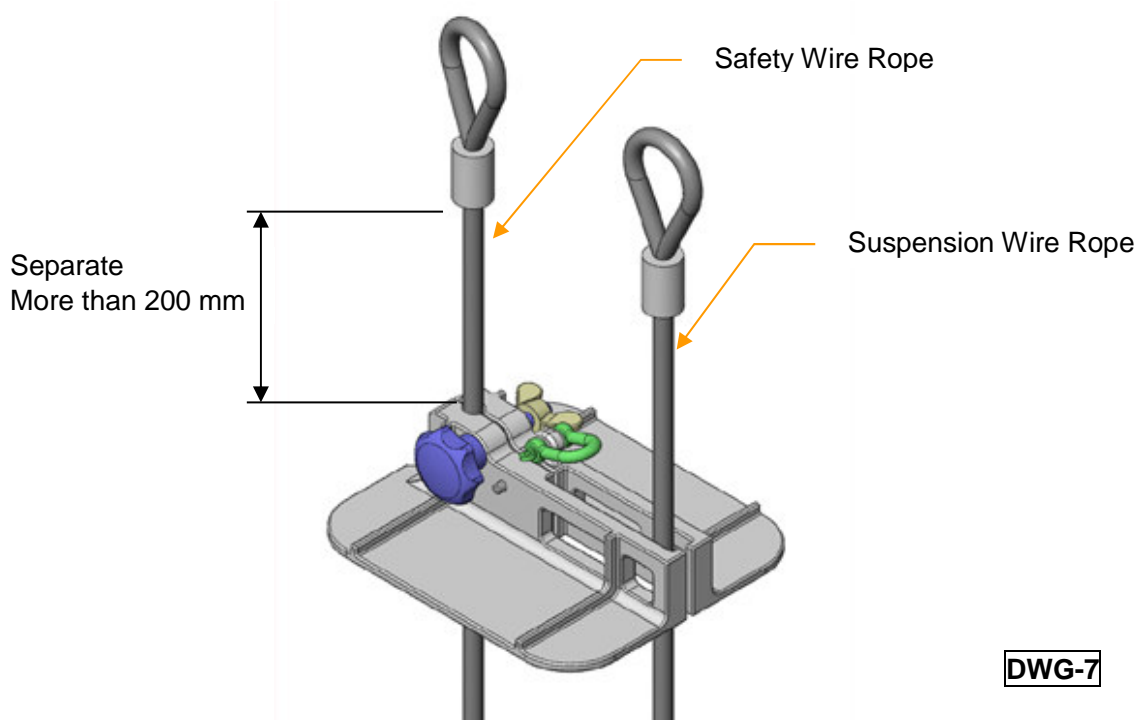

[Installation procedure]

1. Sandwich Suspension wire rope and Safety wire rope with limit detection plates as shown in DWG-8.
The Suspension wire rope installs into the limit detection plates that opening space is larger shown.
2. Tighten a knob (blue knob in DWG-8) until limit detection plates are maintained by friction with wire rope.
3. Then tighten a nut (a yellow butterfly nut in DWG-8) until it hits a wall surface of the limit detection plate.
 - This nut is for loosen prevention of the blue knob, not need to tighten further after hitting the wall.
4. Loosen prevention glue is painted on the screw part of the blue knob, do not tear it off.
5. On the occasion of the installation, use a reserve rope for prevention of fall, and connect the reserve rope to shackle and fix the reserve rope to a suspension point.

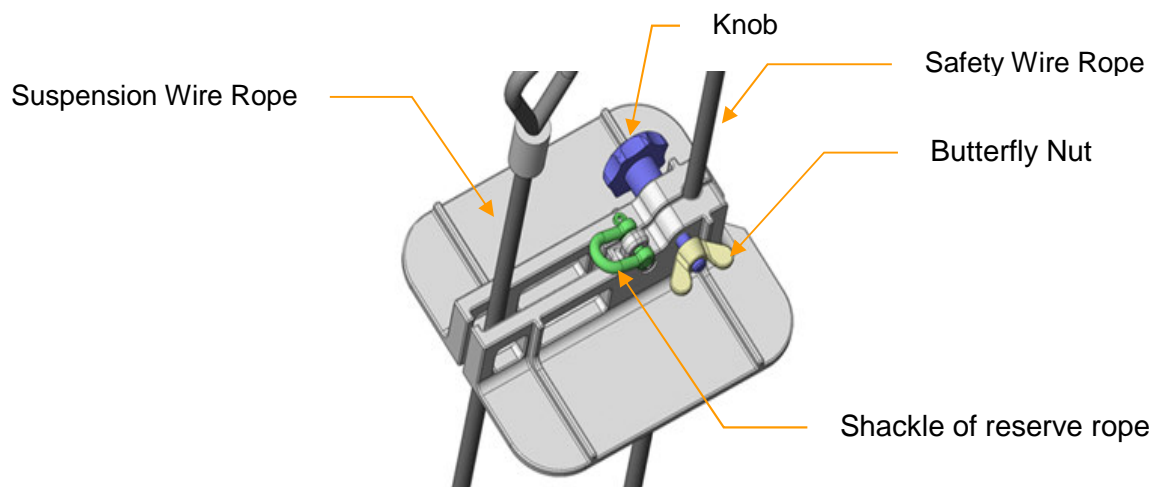

DWG-8

10.3.6. OPERATION / HANDLING METHODS

This section describes the following methods to safely handle and operate of the BISOMAC210.

1. Explanation of operation and safekeeping of BISOMAC210.
2. Explanation of operation methods of BSOMAC210.
3. Explanation of each device's function and feature.

WARNING

1. Each BISOMAC210 operator has to understand the operator's manual and the warning label and manuals before using. If the operator operates the BISOMAC210 improperly, this may cause the platform to fall or tilt, and consequently operators or objects might fall, resulting in serious injury, death or damage to operators or passers-by.
2. DO NOT exceed the maximum load of the BISOMAC210. The rigging portion may fall, resulting in potential of death or injury to operators or passers-by.

(Caution: Safekeeping)

CAUTION

Remove the Overload Detection Device from the BISOMAC210 before storing hoist. Carefully store the hoist so that it does not fall down and become damaged.

(Warning: Lifting and Emergency Stop)

WARNING

1. DO NOT have the Operation Button continuously depressed. Otherwise, the BISOMAC210 cannot stop. This may cause the platform to fall or tilt, and consequently operators or objects might fall, resulting in serious injury, death or damage to operators or passers-by.
2. Always allow the BISOMAC210 to come to a full stop before changing the direction of travel. Failure to do so may result in control circuit failure, or may prevent the BISOMAC210 from stopping. This may cause the platform to fall or tilt, and consequently operators or objects might fall, resulting in serious injury, death or damage to operators or passers-by.
3. DO NOT use the BISOMAC210 if the Emergency Stop Button does not operate. Failure to do so may result in control circuit failure, or may not prevent the BISOMAC210 from stopping. This may cause the platform to fall or tilt, and consequently operators or objects might fall, resulting in serious injury, death or damage to operators or passers-by.
4. DO NOT use the BISOMAC210 if the controlled descent lever is defective, or without the repair and inspection are completed.

 **CAUTION**

Do not operate the BISOMAC210 more than 30 minutes during any 2 hours period. If you do so, the brake surface will become very hot and could result in burns if it is touched.

(Warning: Controlled Descent Lever)

 **WARNING**

1. Use the Emergency Descent Lever only in the event of loss of electric power. Put the Emergency Descent Lever through the hole of the Lever Stopper and attach it with screw after using. Otherwise, the BISOMAC210 may not stop, and this may cause the platform to fall or tilt, and consequently operators or objects might fall, resulting in serious injury, death or damage to operators or passers-by.
2. DO NOT use the Emergency Descent Lever when operating the Operation Button. Otherwise, the BISOMAC210 may not stop, and this may cause the platform to fall or tilt, and consequently operators or objects might fall, resulting in serious injury, death or damage to operators or passers-by.
3. Confirm that the Emergency Descent Lever is in the vertical position and affixed to the Lever Stopper before moving the BISOMAC210 up and down. If the Emergency Descent Lever is not in the vertical position, the Electromagnetic Brake may malfunction. In such case, even if you try to stop the operation of the Operation Button, the brake may not function properly, causing the platform to continue to descend. This may cause the platform to fall or tilt, and consequently operators or objects might fall, resulting in serious injury, death or damage to operators or passers-by.
4. Always operate the Emergency Descent Lever by hand. Otherwise, the BISOMAC210 cannot be stopped instantly. This may cause the platform to fall or tilt, and consequently operators or objects might fall, resulting in serious injury, death or damage to operators or passers-by.

 **CAUTION**

1. Be sure to remove the AC Power Plug of the BISOMAC210 from power source before using the Emergency Descent Lever. Otherwise, sudden movement may be induced when the power is regained. This may cause serious injury, death or damage to operators or passers-by.
2. DO NOT operate the BISOMAC210 by partially releasing the Emergency Descent Lever. Doing so may result in serious burns, overheating of the BISOMAC210 and premature brake wear. If this occurs, the brake may become not repairable.

NOTE: DO NOT use the BISOMAC210 if the platform does not descend using the Emergency Descent Lever. Otherwise, the platform may not descend and it may not be possible to rescue operators in the event of a power failure. DO NOT use the BISOMAC210 until it is repaired and retested.

10.3.6.1 Carrying BISOMAC210

- Separate the BISOMAC210 and overload device to safely carry each device as shown.
- Carry the BISOMAC210 with 2 persons by grasping the carrying grips.
The weight of BISOMAC210: **approximately 48.0kg**
The weight of Safety Devices: approximately 8.5kg (Overload, Fall Arrest, Limit Switches)
- Use the special bolts and nuts of the overload device to connect the BISOMAC210 and each safety devices.

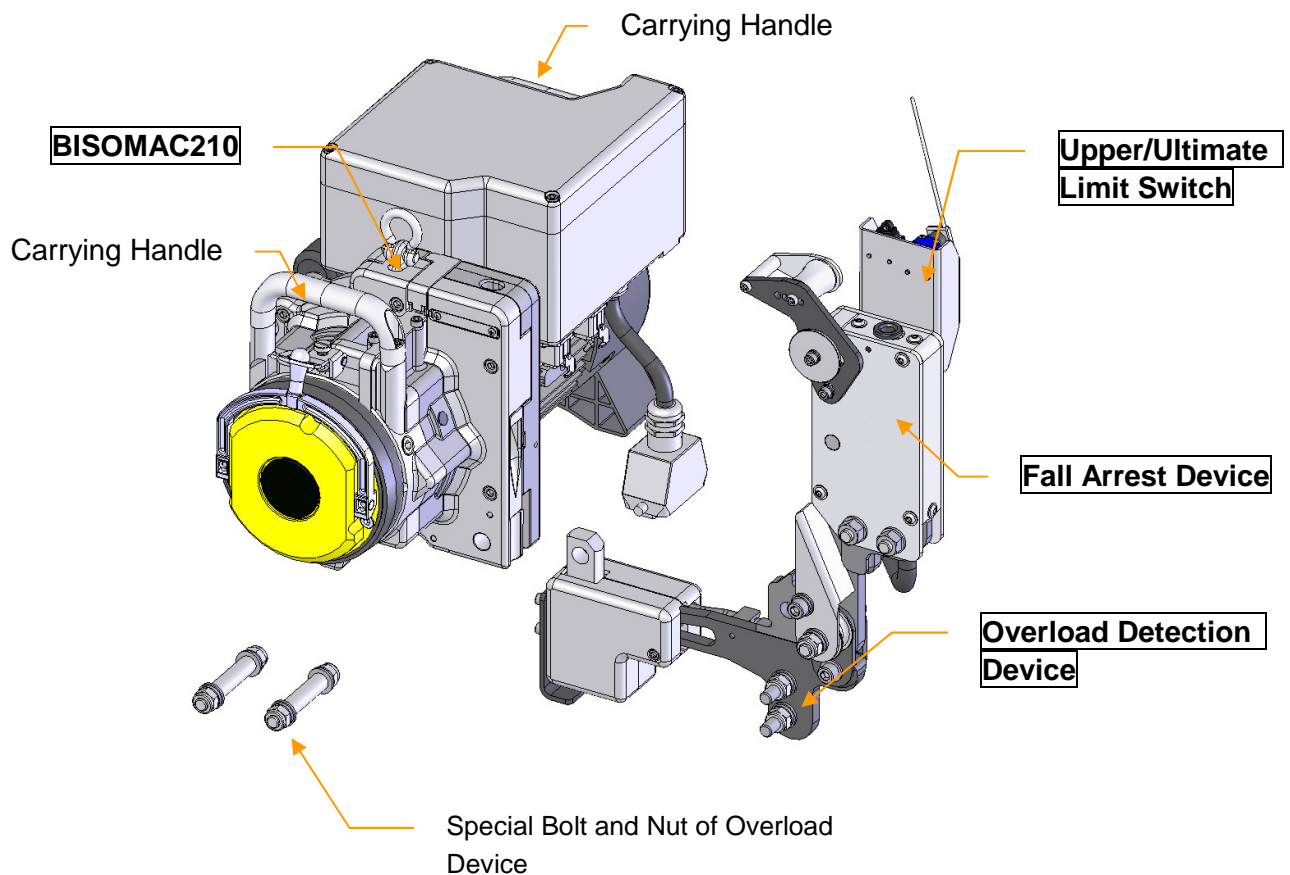

DWG-9

10.3.6.2 Operation and use of Emergency Stop

- Control the BISOMAC210 by operating buttons on the central control box.
- Make sure the BISOMAC210 ascends by pressing “Up” Button and descends by pressing “Down” Button.
- Make sure the BISOMAC210 stops by pressing “Emergency Stop Button” and the BISOMAC210 will not ascend or descend.

10.3.6.3 Emergency Descent Lever

- In the event of loss of electric power, the BISOMAC210 may be lowered at regular speed using the Emergency Descent Lever.
- If you desire to lower the BISOMAC210:
 - 1) Disconnect the AC Power Plug of the BISOMAC210 from Power source.
 - 2) Loosen the Screw and lift the Lever Stopper for the Electromagnetic Brake up. (refer DWG-10)
 - 3) Release the Electromagnetic Brake by gently pulling the Emergency Descent Lever as far as it will go toward the arrow as shown. The BISOMAC210 safely lowers at regular speed.
 - 4) Release hand from the Emergency Descent Lever to stop the BISOMAC210.

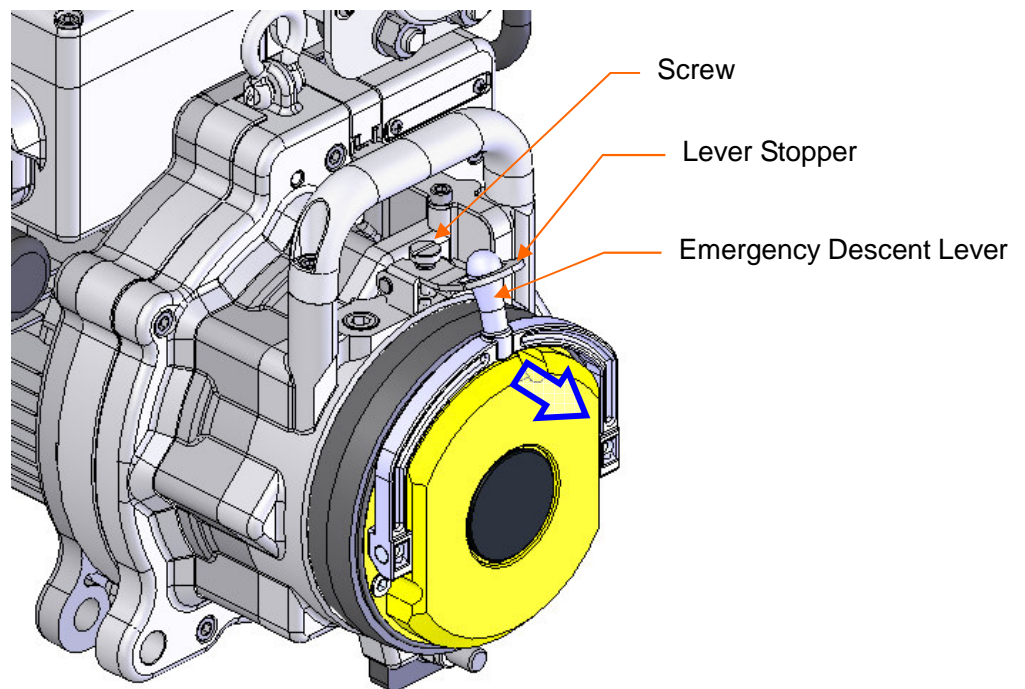

DWG-10

10.3.7. DAILY TESTS AND INSPECTIONS

This section describes necessary test procedure before and after installation of the BISOMAC210.

- Read and understand Steps 7.1-7.6 of this section describing the inspection and installation procedures of the BISOMAC210 before attempting use.
- Follow each devices maintenance manuals if the daily tests and inspections are not described in this manual.

WARNING

1. DO NOT allow anyone under suspended platform. If necessary, provide protection below the suspended platform to prevent potential of death or injury to passers-by from falling objects.
2. NEVER perform any disassembly, maintenance, repair, or part replacement on the BISOMAC210 when it is suspended in air or is under load. This may cause the platform to fall or tilt, and consequently operators or objects might fall, resulting in serious injury, death or damage to operators or passers-by.
3. ALWAYS test and inspect the BISOMAC210 on a daily basis, otherwise the BISOMAC210 may malfunction. This may cause the platform to fall or tilt, and consequently operators or objects might fall, resulting in serious injury, death or damage to operators or passers-by.

(Warning: Test Procedure of Rigging Metal)

WARNING

If the Rigging is in an abnormal condition, STOP to use platform. If the wire rope runs out from rigging or wire rope is cut, this may cause the platform to fall or tilt, and consequently operators or objects might fall, resulting in serious injury, death or damage to operators or passers-by.

(Warning: Test Procedure of Wire Rope)

WARNING

The wire rope will wear out with repeated operation. Therefore, it must be regularly inspected to be sure it is in good condition. If you use a wire rope that is deformed or damaged, it will have reduced strength and may break. This may cause the platform to fall or tilt, and consequently operators or objects might fall, resulting in serious injury, death or damage to operators or passers-by.

(Warning: Test Procedure of Lifting Platform and Emergency Stop Function)

WARNING

1. If you hear any strange noises such as grinding during operation or if the BISOMAC210 does not appear to work normally, stop it immediately. DO NOT

- continue to use the BISOMAC210 until it is replaced. It is possible that parts inside the BISOMAC210 have been damaged. Continuing to use the BISOMAC210 may cause the platform to fall or tilt, and consequently workers or objects might fall, resulting in possible death or injury to workers or passers-by.
2. If the BISOMAC210 is suspended in the air and the motor is running but the wire rope is not moving through the BISOMAC210, stop the BISOMAC210 immediately. Damaged wire rope may be jammed inside the BISOMAC210. Any attempt to move the BISOMAC210 up or down can damage the equipment and/or sever the wire rope ends, making BISOMAC210 unable to sustain load. This may cause the platform to fall or tilt, and consequently workers or objects might fall, resulting in possible death or injury to workers or passers-by.
 3. Do not use the BISOMAC210 if the Red Lamp does not led even emergency stop button is pressed. Otherwise, the Emergency Stop device does not operate and this may cause the platform to fall or tilt, and consequently workers or objects might fall, resulting in possible death or injury to workers or passers-by.

(Warning: Test Procedure of Controlled Descent Device)

 **WARNING**

If the BISOMAC210 has a defect, replace it with one that has passed the pre-shipment inspection by certified personnel. A BISOMAC210, which has not passed the pre-shipment inspection, may malfunction or not perform normally. This may cause the platform to fall or tilt, and consequently operators or objects might fall, resulting in serious injury, death or damage to operators or passers-by.

(Warning: Test Procedure of Fall Arrest Detection Device)

 **WARNING**

DO NOT use the BISOMAC210 if the fall arrest detection device does not engage the wire rope. Replace it with a properly operating Overspeed Detection Device, failure to do so may cause the suspension wire rope to be cut, the platform to fall or tilt, and consequently operators or objects might fall, resulting in serious injury, death or damage to operators or passers-by.

(Warning: Test Procedure of Upper/Ultimate Limit Switch)

 **WARNING**

DO NOT use the BISOMAC210 if the Upper/Ultimate Limit Switch does not operate properly. Stop to use it and replace it with good condition fall arrest detection device, failure to do so may cause suspension wire rope cut, the platform to fall or tilt, and consequently workers or objects might fall, resulting in potential of death or injury to workers or passers-by.

10.3.7.1 Test Procedure for Rigging

Inspect all components of the suspended platform, especially the components supporting loads, to be sure there are no signs of damage or excessive wear and that all fasteners (nuts, bolts, clamps, wire-clip, shackle, etc.) are properly and securely tightened.

10.3.7.2 Test Procedure of Wire Rope

10.3.7.2.1 Wire Rope and profile and dimension

- Wire rope MUST be taken out of service when ANY of the following conditions apply: (refer PHOTO-1)

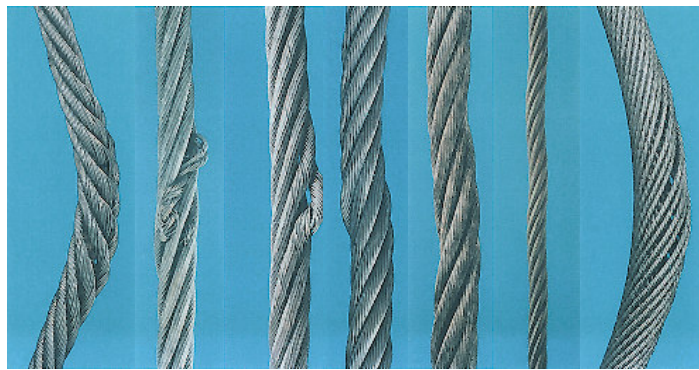

PHOTO-1

- 1) Loose, kinked, crushed, bird caged wire rope, waviness (more than $4/3d$) or any damage resulting in distortion of the rope structure.
- 2) More than 10% broken wires in one pitch (one lay). The DWG-11 shows 1 pitch of 6 stand wire rope case.

Example: Wire Rope construction 6 x 19

$$6 \times 19 = 114 \text{ wires} \times 10 \% = 11 \text{ wires}$$



DWG-11

- 3) Reduction of wire rope diameter's average: under 8.8 mm.
- 4) Increase of wire rope diameter's average: exceed 9.5 mm.
- 5) Pitting on wire surfaces due to rusting corrosion.
- 6) Evidence of exposure to temperatures above 200° F (93° C).

- Measure the diameter across the widest part of the strands, not the valleys, when the rope is under load. Several places are measured in the direction of length of the rope.

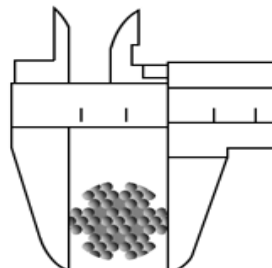

DWG-12

NOTE: DO NOT use wire rope that has been worn, kinked, bird caged or damaged. Replace it with new wire rope

10.3.7.2.2 Preparation of the end of the wire rope

- The end of the wire rope must be prepared for insertion of the BISOMAC210 as shown in the photo-2.

NOTE: Improperly prepared bullet can cause the wire rope to jam in the BISOMAC210 and the wire does may get stuck in the hoist.

- The end of the wire rope treatment is as shown in the photo-2.

Wire rope diameter: 9 – 9.5 mm

Braze distance: within 10mm

Top Radius: R5mm

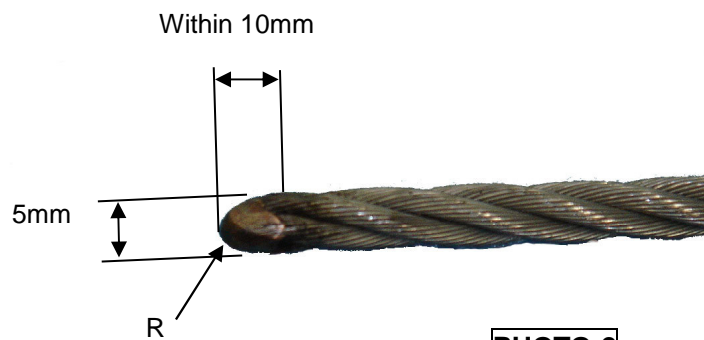

PHOTO-2

10.3.7.3 Test procedures for Lifting and use of the Emergency Stop

- 1) Make sure the BISOMAC210 is connected to the stirrup properly and the cable is connected to connection plug properly.
- 2) Raise the platform about 100cm off the ground and then lower it to its original position. Repeat this procedure several times.
- 3) Press the emergency stop button located central control box to disconnect the power to the BISOMAC210.
- 4) Make sure that the Indication light for the Emergency Stop Button is lit.
- 5) Press the UP/DOWN buttons to confirm that the BISOMAC210 will not operate.
- 6) Reset the emergency stop button to confirm that the BISOMAC210 will operate.

10.3.7.4 Test procedures for Controlled Descent Device

- 1) Raise the platform about 100cm off the ground.
- 2) Remove the connection plug to disconnect the power to the BISOMAC210.
- 3) Remove Fix Bolt and lift safety lock for electromagnetic brake up.
- 4) Release the electromagnetic brake by gently pulling the controlled descent lever as far as it will toward you.
- 5) The platform should descend at a controlled speed not greater than 9 m/min.

If the descent speed exceeds 9m/min. contact local BISOMAC210 distributor.

10.3.7.5 Test procedures of Fall Arrest Detection Device

The following is same as **STEP 6** Operation Confirmation of Fall Arrest Device

1. Raise the platform approximately 2 m from ground.
2. Descend one side of hoist by operating the central control box.
3. Make sure that Fall Arrest Device engages the safety wire rope.
4. Raise the platform to reset the Fall Arrest Device.
5. Perform same procedure to other side of Fall Arrest Detection Device.

If the fall arrest detection device will not engage the safety wire rope, ask contact local BISOMAC210 distributor. to replace with new one.

If the angle of the platform inclination exceeds 14 degree, ask the authorized trained personnel for adjustment.

Refer the attached maintenance manual for the adjustment.

10.3.7.6 Test procedures of Upper/Ultimate Limit Switch

1. Push one side of Upper Limit Detection Lever down and press the UP button on the Central Control Box to attempt to rise.
2. The BISOMAC210 where pushed the Lever down does not rise. Refer DWG-13.
3. Push Down button of the Central Control Box with pushing the Lever down.
4. The Both side of BISOMAC210 descent.
5. Next, press the Roller of the Ultimate Detection Device and press the UP bottom to attempt to rise. Refer DWG-13.
6. The both side of BISOMAC210 does not rise.
7. Push a Down button of the Central Control Box while pressing the Roller of the Ultimate Detection Device.
8. The both side of BISOMAC210 does not rise.
9. Perform same procedure to other side of the BISOMAC210.

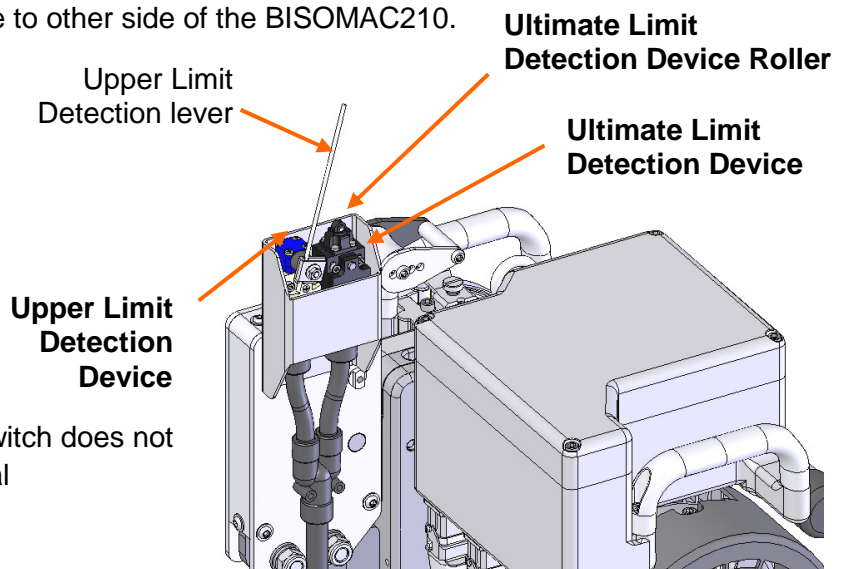

If the Upper/Ultimate Limit Switch does not operate properly, contact local BISOMAC210 distributor.

DWG-13

10.3.8. PERIODIC INSPECTIONS

The BISOMAC210 has to conduct the following periodic inspections if the BISOMAC210 experiences the following conditions. The periodic inspections have to be performed by certified personnel.

The following time periods should be used to determine to perform periodic inspections. However, depending on job and environmental conditions, periodic inspections may need to be done sooner.

- 1) Unit is more than 1 year old after purchasing
- 2) Unit over 1 year after previous periodic inspection
- 3) Unit operation hour is over 100 hours since last periodic inspection
- 4) When BISOMAC210 used in a bad work environment, such as dirt, dust, etc.

Follow maintenance manual (see Hoist Maintenance Manual) concerning periodic inspections.

 **WARNING**

1. ALWAYS test and inspect the BISOMAC210 on a daily basis, otherwise the BISOMAC210 may malfunction. This may cause the platform to fall or tilt, and consequently operators or objects might fall, resulting in serious injury, death or damage to operators or passers-by.
2. ALWAYS test and inspect the BISOMAC210 on a daily basis especially in work environments that contain contaminants. Maintain hoist (see maintenance manual) after completing work at each work site to remove dusts and foreign objects inside of hoist. Failure to do so may cause the platform to fall or tilt, and consequently operators or objects might fall, resulting in serious injury, death or damage to operators or passers-by.
3. Only trained and certified personnel may replace the brake, motor, or gearbox. Otherwise, the BISOMAC210 may malfunction or not perform normally. This may cause the platform to fall or tilt, and consequently operators or objects might fall, resulting in serious injury, death or damage to operators or passers-by.
4. DO NOT replace any BISOMAC210 parts with ones that are not approved. Such replacement may cause the BISOMAC210 to malfunction or not perform adequately. This may cause the platform to fall or tilt, and consequently operators or objects might fall, resulting in serious injury, death or damage to operators or passers-by.

10.3.9. TROUBLESHOOTING AT JOB SITE

(Problem from Mishandling)

The following information is intended to help identify faults that can occur and recommended correction(s).

 WARNING
<p>If the problems (case 1 – case 8) cannot be solved by performing the corrective measures below, replace the hoist or contact local authorized BISOMAC210 distributor. All repairs and solution of these problems must be performed by trained and certified service personnel, otherwise, this may cause the platform to fall or tilt, and consequently operators or objects might fall, resulting in serious injury, death or damage to operators or passers-by.</p>

Problem	Probable Causes	Measures method
<div style="border: 1px solid black; display: inline-block; padding: 2px 5px; margin-bottom: 5px;">CASE (1)</div> Press UP or Down Buttons, BUT BISOMAC210 will not operate.	Main power is not connected.	Confirm the main power connection and power connections are proper.
	Emergency Button is pushed.	Check the Emergency Buttons lamp and reset the Emergency Button.
	Ultimate Limit Switch is activated.	Confirm that there is no obstruction that made Ultimate Limit Switch activation.
	Upper/Ultimate Switch's connection is disconnected.	Check the Upper/Ultimate Switch's connection
	Overload protection feature is activated due to overload.	Unload the weight in platform.
Problem	Probable Causes	Solution
<div style="border: 1px solid black; display: inline-block; padding: 2px 5px; margin-bottom: 5px;">CASE (2)</div> Press UP Button, BUT, BISOMAC210 will not ascent.	Overload Detection Device's connection is disconnected.	Check the Overload Detection Device's connection
	Upper Limit Switch is activated.	Confirm that there is no obstruction that hit Upper Limit Switch activation.
	Weight is exceeded.	Unload the weight in platform
	Voltage is too low.	Supply power within allowable power of BISOMAC (see 2.1)
	Power Cable is too long or size is too small.	Shorten power cable or use larger size.

Problem	Probable Causes	Solution
CASE (3) Motor runs but hoist will not self-reeves	Inadequate bullet on the wire rope.	Make sure the proper wire rope is used. (see 7.2.2)
	Wire rope is worn or damaged.	Replace wire rope.
	The exit of wire rope is blocked.	Remove obstruction which caused blockage.
Problem	Probable Causes	Solution
CASE (4) Hoist self-reeves, but will not lift platform	Inadequate wire rope is used.	Make sure the proper wire rope is used. (see 2.2)
	Wire rope is worn or damaged.	Replace wire rope.
Problem	Probable Causes	Solution
CASE (5) BISOMAC210 ascending speed is too low.	Power voltage is too low	Check that voltage and power cable are correct (see 2.1) Supply proper voltage.
	Wire rope is worn or damaged.	Replace wire rope.
Problem	Probable Causes	Solution
CASE (6) BISOMAC210 makes unusual noise	Each device's fix bolts and nut is loosened.	Check them and tighten properly.
Problem	Probable Causes	Solution
CASE (7) BISOMAC210 is too hot	Voltage of input power is too high	The supply voltage should not exceed +10% (see 2.1)
	Air supply to Motor is in bad condition	Improve air ventilation on protection cover of BISOMAC210
	Frequency use of BISOMAC210	Strict observance of BISOMAC210 operation hours (see 6)

Problem	Probable Causes	Solution
<p style="text-align: center;">CASE (8)</p> <p><i>Fall Arrest Detection Device activates.</i></p>	There is kink, deformation on safety wire rope	Stop the operation of BISOMAC210 immediately and replace it with good condition wire rope.
	The diameter of the safety wire rope is thick.	Confirm the wire rope diameter (see 7.2.1) and replace it with good condition wire rope.

Revise History:

1-phase 230V Hoist Schematic Diagram

